



ITEM NO. 11173

# UPSIDE - DOWN OVERPASS

## BEFORE YOU BEGIN ...





### WARNING: CHOKING HAZARD

Contains small parts. Not for Children Under 3 Years

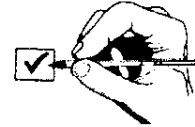
1. Unpack the parts. Save the packing materials.
2. Match the parts to the drawings below.
3. If you have each part, put a check in the box next to the picture of the part. Look in the carton again and check all of the packing materials to make sure you haven't missed anything.

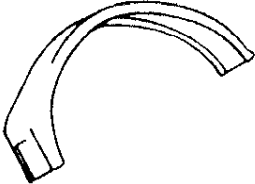
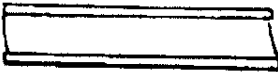
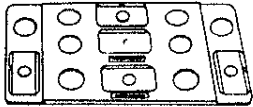

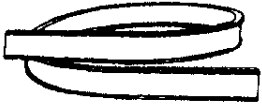
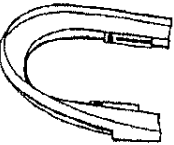
- |  |  |  |
|--|--|--|
|   |   | <input type="checkbox"/> 1 - DARDA CAR (not pictured)                                |
| <input type="checkbox"/> 8 - LOOP HALVES   | <input type="checkbox"/> 2- 7" STRAIGHT TRACKS                                     |   |
|  |   | <input type="checkbox"/> 2 - LARGE BASE PLATES                                       |
| <input type="checkbox"/> 8 - LOOP JOINERS  | <input type="checkbox"/> 4 - TRACK JOINERS   |  |
|  |  | <input type="checkbox"/> 1- 16.5" FLEX TRACK   |
|  | <input type="checkbox"/> 2 - FLEXI CURVES  | <input type="checkbox"/> 1- 41" FLEX TRACK   |

## IF A PART IS MISSING OR DAMAGED ...

The store where you purchased this item does not have parts. You will get the easiest service from **Darda Inc., USA**. Tell us the part(s) needed and be sure to include your name and address printed clearly. Mail to: **DARDA INC., USA** / 1600 Union Avenue / Baltimore, MD 21211 / ATTN: Dock 2

## STEP ONE - Make 4 loops.

- To make each loop, put two loop halves together so that the pins at the top of each loop half go into the proper holes, creating a tight fitting seam between the two loop halves.
- Holding the loop halves together, slide one loop joiner over one end of the seam and the other loop joiner over the other end of the seam.
- Repeat this step four times to make four loops from the 8 loop joiners and 8 loop halves in this set.

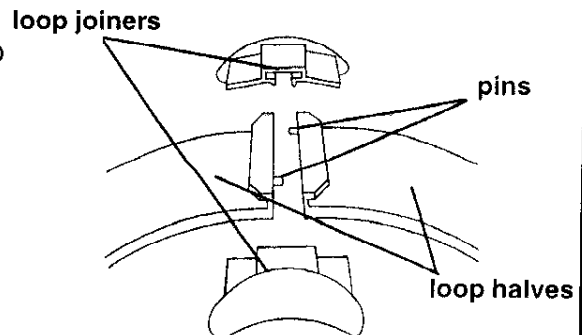

## STEP TWO - Attach straight track to large baseplates.

Refer to figure 1

- Position the **large baseplates** as shown in **figure 1**. Attach a **7" straight track** to the built in track joiners on either end of **baseplate 2** by sliding one end of each of the **7" straight tracks** over half of the built in track joiners.
- Next, connect the baseplates using the **16.5" flex track**. Attach the flex track in the same way as the straight track. Your track should now look like **figure 1**.

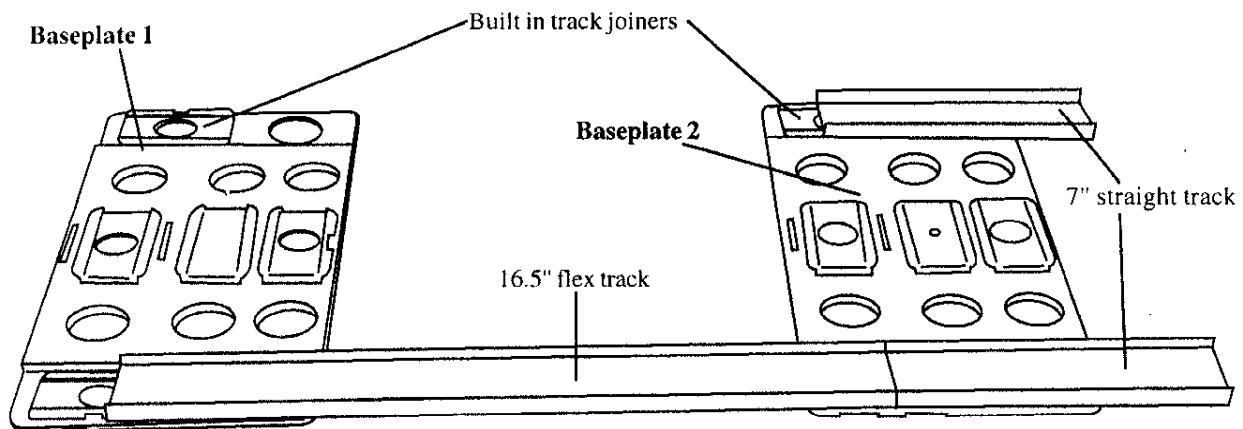

FIGURE 1

## STEP THREE - Attach the loops.

- Select 2 of the loops you made in STEP ONE of these instructions. Take the first loop, **LOOP A** and attach it to **baseplate 1** by sliding the open ends of the loop halfway over the built in loop joiners as shown in **FIGURE 2**. Now take the second loop, **LOOP B**, and attach it to **baseplate 2** as shown in **FIGURE 2**.

- Locate the remaining two loops, Loops C and D. Attach **Loop C** by sliding one end halfway over the middle built in track joiner on **baseplate 1**. Be sure the loop meets flush with LOOP A and that there are no gaps. Now twist the other half of the loop around and slide it halfway over the built in track joiner located at the end opposite the 16.5" flex track on baseplate 1. Refer to **FIGURE 3**.

- Attach **Loop D** to **baseplate 2** as shown in figure 3 by sliding one half of the loop over the built in track joiner to meet LOOP B. Twisting the opposite end around, slide it over the built in track joiner to meet the 7" straight track. Be sure the tracks meet flush and that there are no gaps.

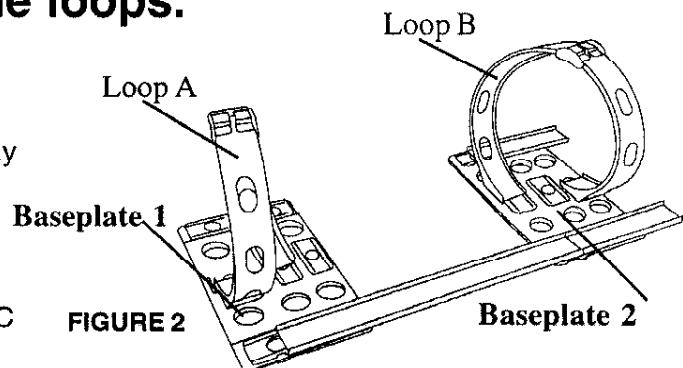

FIGURE 2

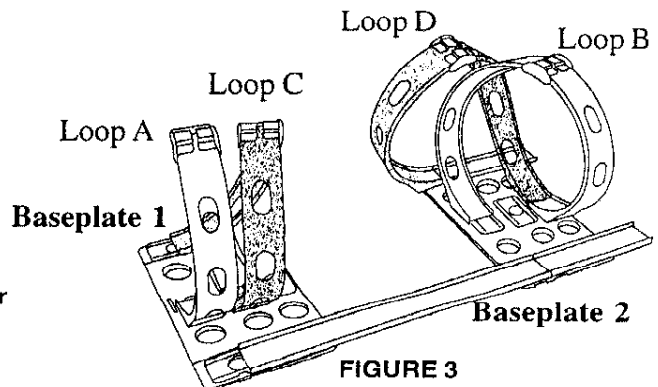

FIGURE 3

## STEP FOUR - Attach the flexi curves

- Attach the flexi curves to the built-in track joiners on both ends of each base plate by sliding each end of the flexi curve over the built-in track joiners. Be sure there are no gaps and that the track joiners are completely covered.
- Your track should now look like figure 4.

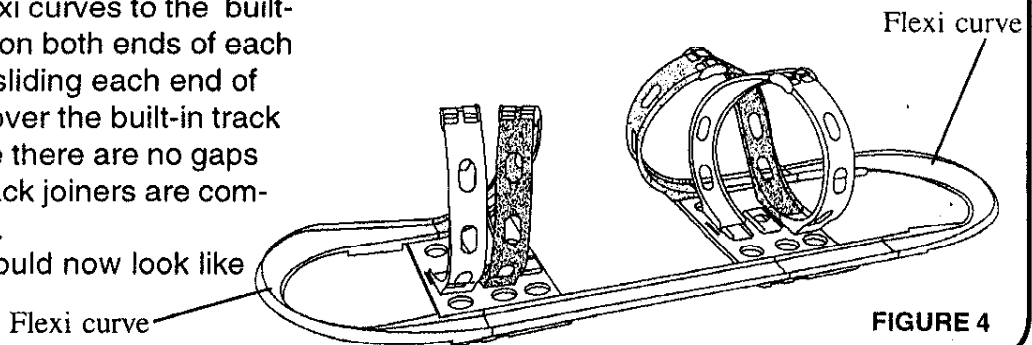

FIGURE 4

## STEP FIVE - Complete the track

- Complete the track layout by sliding one end of the 41" flex track onto the open end of the built in track joiner of **LOOP B** on **baseplate 2**. Guide the flex track over and around to **baseplate 1** and attach the other end to the open built in track joiner of **LOOP A**. See **FIGURE 5**.

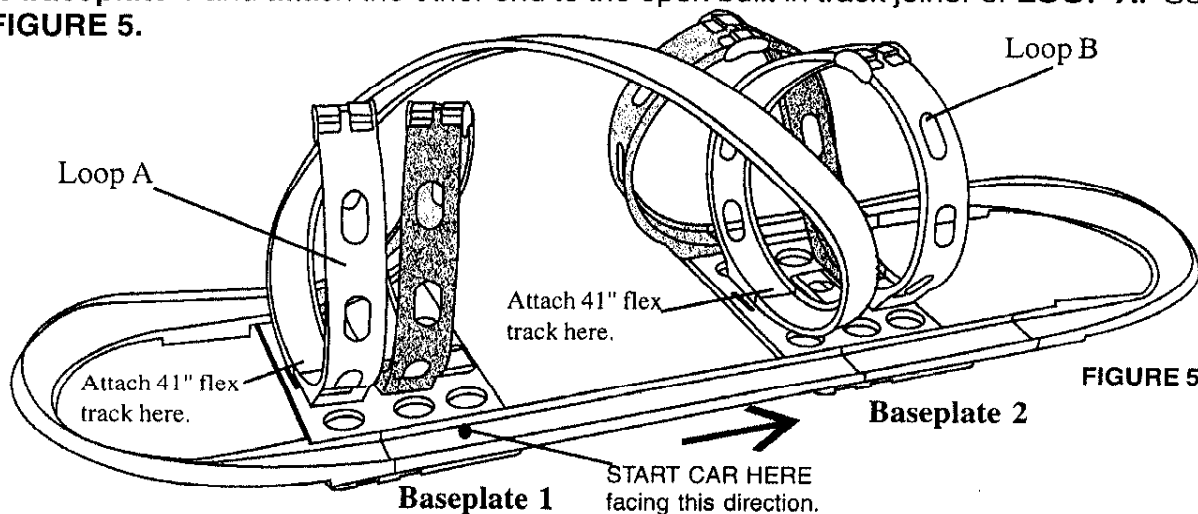
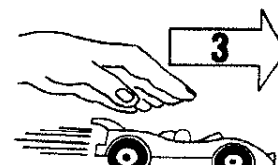
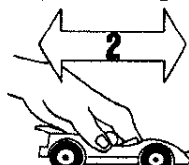
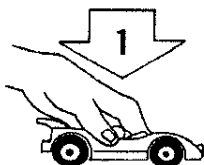

FIGURE 5

## STEP SIX - Get set, go!

Place your car on the track as indicated in figure 5 above.

1. Press down on car body until you hear a click.
2. While still pressing down, roll car back & forth until the clicking sound gets louder.
3. Lift your hand up off the car while rolling forward. Watch it go!



### Tips

- Be sure that the car is fully wound by listening for the click to get louder before releasing it.
- Have fun with your Darda cars on or off the Darda track. For longer life **do not** run cars on carpet.
- Replacement motors are available at your local specialty toy store; or contact Darda Inc., USA at the address on page 1 of these instructions.

## ALTERNATE TRACK LAYOUTS

Create the two track layouts below from the pieces in this set.

### Alternate #1

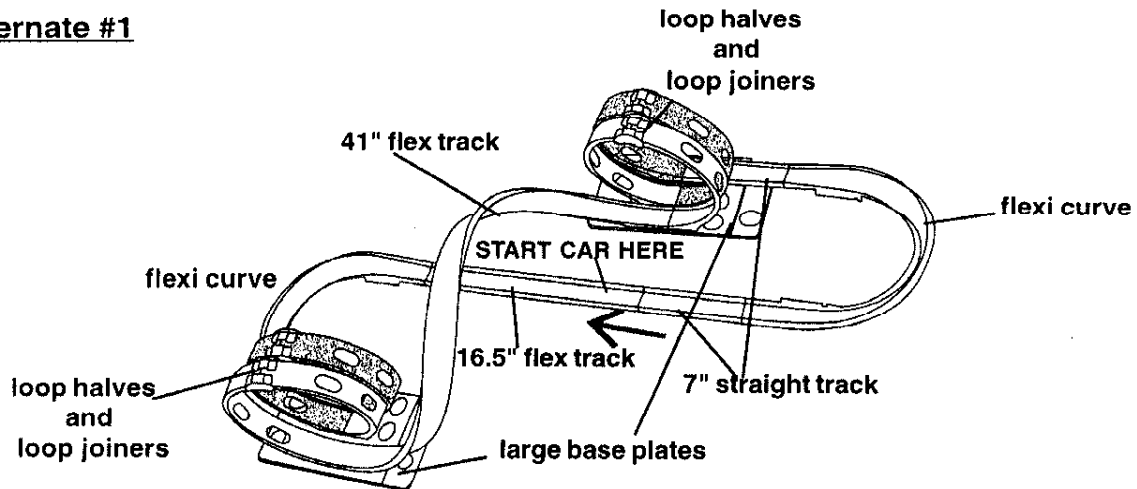

### Alternate #2

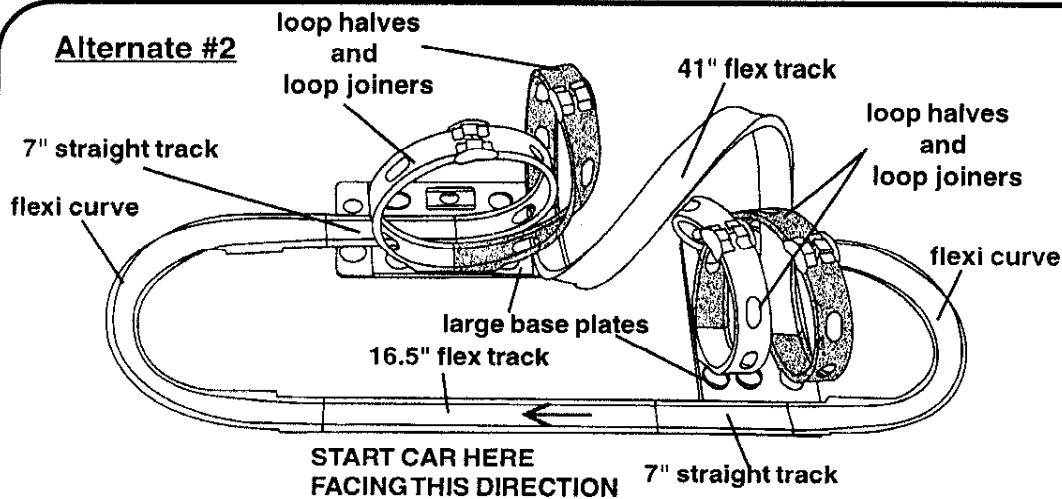

## TRACK TIPS

- If your car has trouble making it around the track at first try the following
  1. Be sure that all track seams meet and connections are secure. Track pieces must meet flush against each other where they are connected with track and loop joiners, without gaps or bumps at the joints.
  2. It may be necessary to play with, adjust, or slightly bend loops in track layouts to maximize performance. Remember Darda Track is flexible.
- Darda track layouts can be set up on any flat surface. While it is not ideal, your track can be set up on carpet. We **do** recommend dusting off the track before use so that dust particles for the carpet do not jam the motor in your car. We **do not** recommend running the car itself on carpet.

## PROBLEMS ?

Double check your assembly instructions, if you still have difficulty we want to help! Call our toll-free consumer hotline ... **1-800-638-1470**. Mon. - Fri., 9:00 A.M. - 3:30 P.M. (Eastern Standard Time)