

# Darda™

ITEM NO. 11147

## WORLD CLASS POWER LOOPS



### BEFORE YOU BEGIN ...

1. Unpack the parts. Save all the packing materials.
2. Match the parts to the drawings below. If you have each part, put a check in the box next to its drawing.
3. Look in the carton again and check all of the packing materials to be certain you haven't missed anything.
4. Make sure you are familiar with each part's appearance and name. This will help a lot when you start to build your layout!

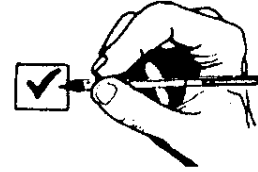

**DUE TO SMALL PARTS, THIS SET IS NOT RECOMMENDED FOR CHILDREN UNDER 4 YEARS OF AGE**

### PARTS LIST

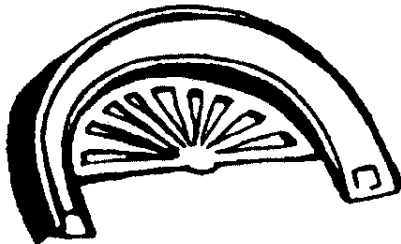

1 180 DEGREE CURVE

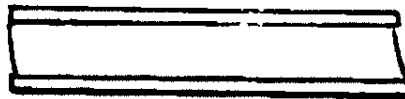

2 14" STRAIGHT TRACK

2 7" STRAIGHT TRACK



1 DARDA CAR

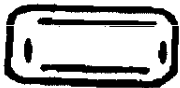

4 TRACK JOINERS

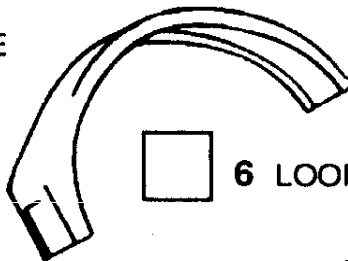

6 LOOP HALVES



6 LOOP JOINERS



1 LARGE BASEPLATE

#### IF ANY PARTS ARE MISSING OR DAMAGED:

The store where you purchased this item does not have parts. You will get the easiest service from **Darda, Inc. USA**. Tell us which part(s) are needed and include your name and address. Please print clearly. Mail to: **Darda, Inc. USA** / 1600 Union Avenue, Baltimore, MD 21211/Attn: Dock 2. Or, call the toll-free number on Page 4.

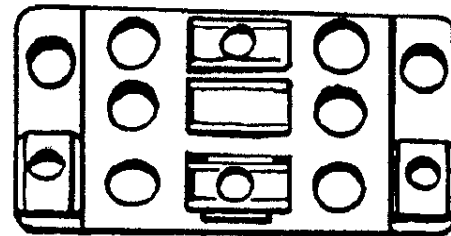

# Da

## STEP 1

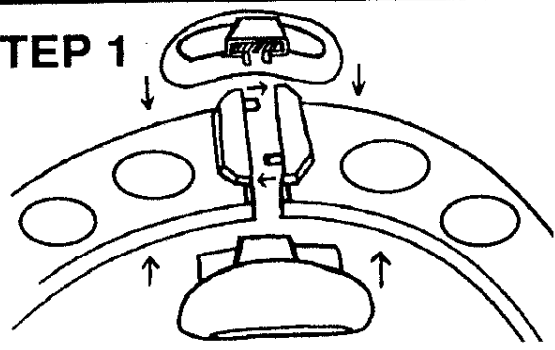

## CREATE THE LOOPS

To make each loop, put two loop halves together so that the pins go in the proper holes. Slide on two loop joiners to connect. Make all **three** loops before you move on to Step 2.

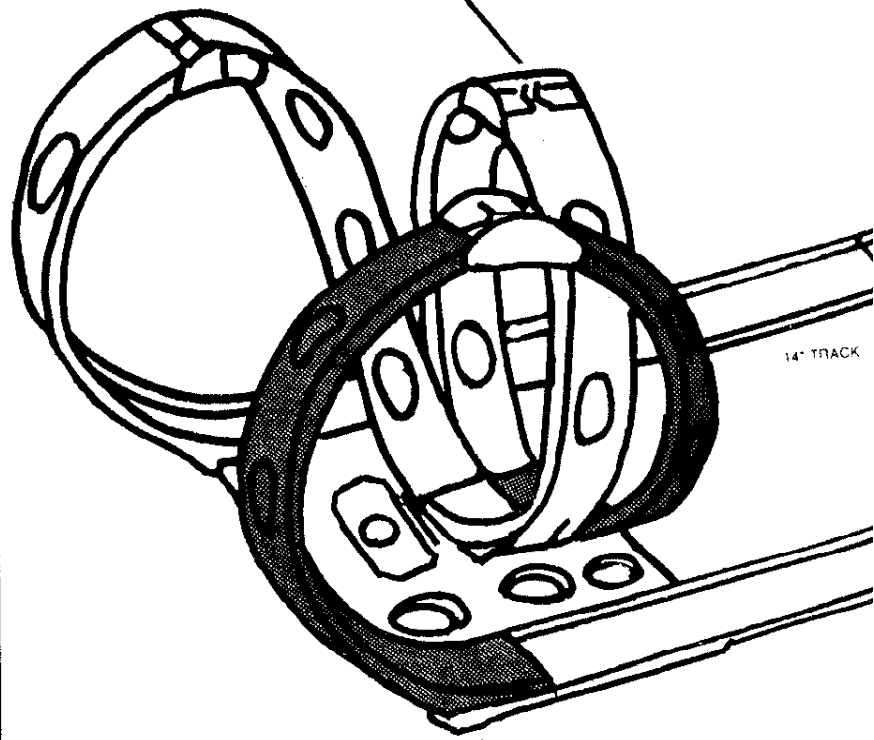

## STEP 2

### CONNECT LOOPS AND TRACK TO LARGE BASEPLATE

Slide a 14" track section halfway onto the baseplate's grooves, making sure the grooves are positioned in the back. Slide a loop half onto the other side of the grooves, joining with the track.

Slide the remaining loops and 14" track onto the baseplate as shown in the diagram. Make sure there are no gaps!

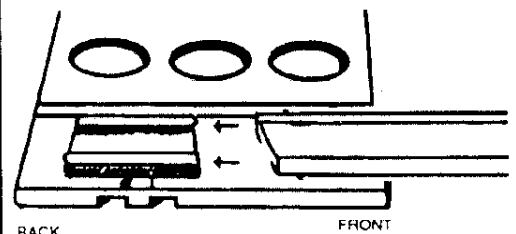

# POV LO

**da**™

### STEP 3 CONNECTING THE TRACK

Use track joiners to connect the remaining track sections, and also the 180° curve. Slide the track over only half of the joiner, leaving room for another section of track to cover what's left. Make sure there are no gaps!

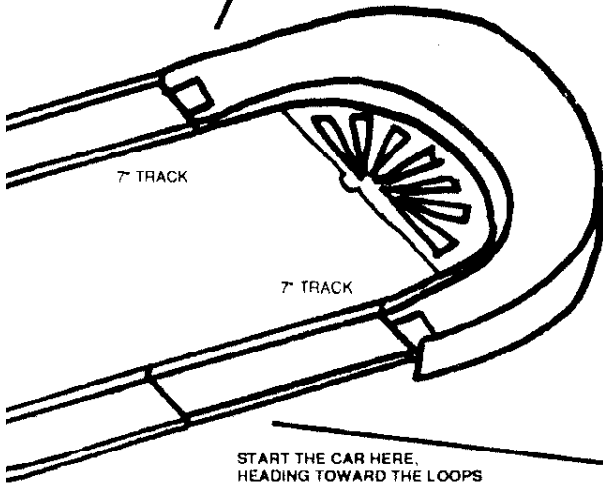
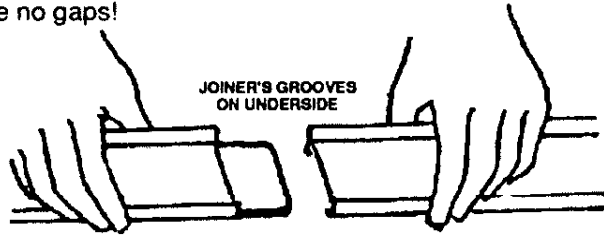

### STEP 4 GET SET, GO!

Place your car in the correct position on the track. Push down on the car's body and roll it back and forth until the clicking sound gets significantly louder. (Don't worry; you can't overwind your Darda Mega-Motor!)

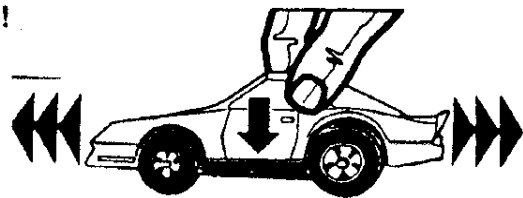

Roll the car up to the starting point, and release it as you're moving it forward. Don't push or throw it --- by letting go as you're rolling it you avoid "spin-out."

To keep your Darda car in top form, frequently wipe dust off the track and rear wheels of the car. Although the car works on or off Darda track, you should never run it on shag or high pile carpet. Replacement motors are available at your local toy specialty store; or see the address for Darda on Page 1.

VER  
PS

## YOU CAN BUILD OTHER LAYOUTS, TOO!

Darda track sets are very versatile, and you can build many different layouts from this one set now that you know how to put the parts together. The two alternates on this page will get you started. After that ...

**USE YOUR IMAGINATION!**

### ALTERNATE LAYOUT #1

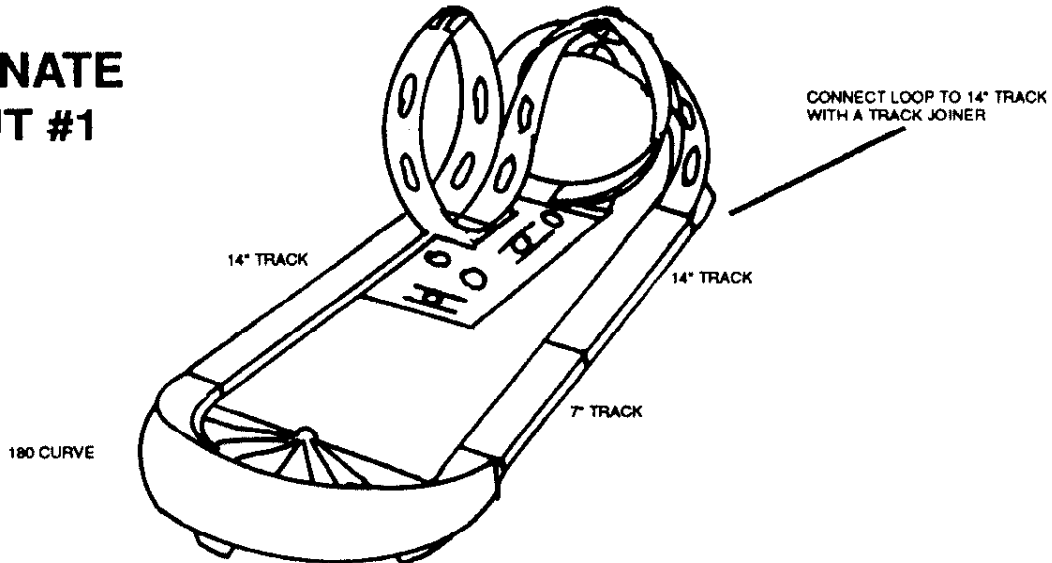

### ALTERNATE LAYOUT #2

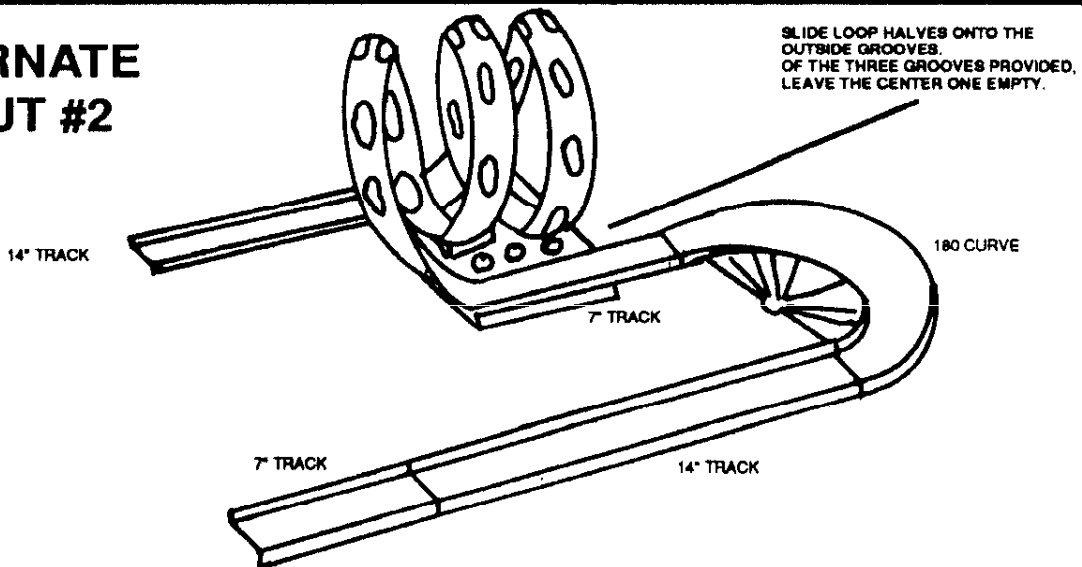

### PROBLEMS?

Remember, the Power Loops set presents a difficult challenge for your Darda car. It might take several attempts before you can complete the route twice. If you have consistent trouble ...

Re-check your assembly instructions. Make sure your track has no gaps, is stable, and set up on a flat surface. If something is still wrong, we want to help! Call our toll-free consumer hotline ...

**1-800-638-1470**

Monday - Friday, 9:00 am - 3:30 pm (Eastern Standard Time)